

32" 3D 4K Medical Display

FM-E3204DGC Rev.01



- HDR support (DisplayPort, HDMI, SDI).
- 3D (X-POL™) ready.
- Expanded intuitive OSD interface.
- Fast detection of MIS camera system video.

3D Technology for the OR

Using specialized imaging systems, 3D visualization allows medical professionals to see spatial relationships and more life-like depth perception during a procedure. FM-E3204DGC Rev.01 delivers super-sharp images using both 2D and 3D video sources. The clarity and color of 4K UHD brings out the best in all types of surgical images.

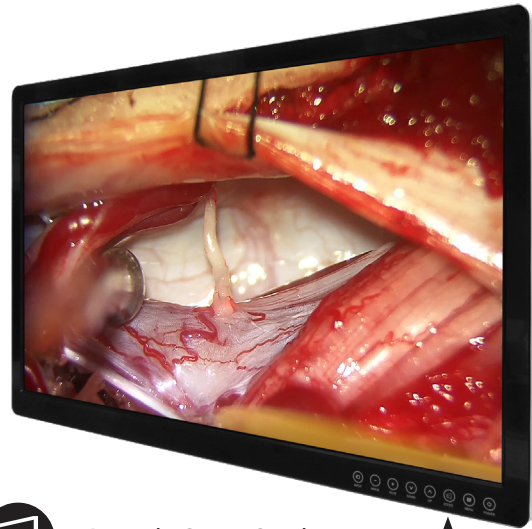

3D mode ON or OFF button.

Use the OSD interface to select 2D or 3D mode, and to adjust 3D settings. Multi-window layouts can also be selected using the OSD interface.



3D eyewear that brings out the best in 3D technology is provided with each display monitor.

The technology designed into FM-E3204DGC Rev.01 produces superior color, sharpness, and functionality in clinical environments. Set-up and connections are simple. FSN monitors are well known for their fast detection of compatible video signals.

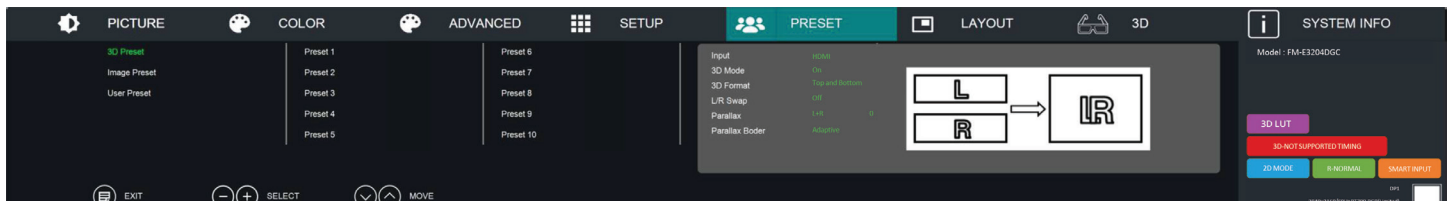
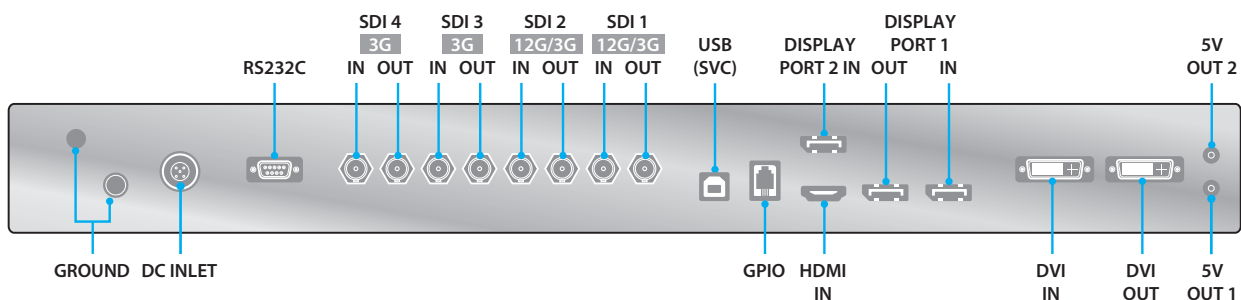

The FM-E3204DGC Rev.01 on-screen display (OSD) offers detailed user control menus.

32" 3D 4K Medical Display

FM-E3204DGC Rev.01



Specifications

General Features

Item	Description
Panel	32 inch TFT LCD (LED)
Resolution	3840 x 2160 pixels
Active Area	708.48 (H)mm x 398.52 (V)mm
Pixel Pitch (mm)	0.1845 x 0.1845
Response Time (typical)	9 ms (gray to gray)
Number of Colors	1.07 Billion
3D Type	Side-by-side, line-by-line, top bottom, SDI level B-DS, SDI dual input
Brightness (typical)	(2D) 700 cd/m ² (3D) 300 cd/m ²
Gamut	BT.709 and BT.2020 compatible
Contrast Ratio (typical)	1750 : 1
Surface Treatment	Anti-glare
Viewing Angle (CR>10)	(2D) R/L 178°, U/D 178° (3D) U/D 16°
Input Signal	1 x HDMI 2.0 (HDCP 2.3)
	2 x DP 1.2 (SST)
	1 x DVI (single link, compatible HDMI 1.4 and HDCP 1.4)
	4 x SDI (3G), 2 x SDI (12G)

Item	Description
Output Signal	1 x DP 1.2 (SST)
	1 x DVI (single link, HDCP 1.4)
	4 x SDI (3G), 2 x SDI (12G)
Power Supply	AC/DC Adaptor (AC 100~240V, DC 24V/6.6A)
Power Consumption	135W max
Accessories Included	User manual, AC-DC adaptor, AC power cord, DP cable, HDMI cable, DVI-D cable, SDI cable, 3D glasses, Screw BH M4 x 14 - 4 pcs.
Latency	1.2 ms
Unit Dimension	760(W) x 465(H) x 71.4(D) mm 29.92(W) x 18.31(H) x 2.81(D) inch
Package Dimension	905(W) x 744(H) x 230(D) mm 35.63(W) x 29.29(H) x 9.06(D) inch
Weight	11.6 kg, 25.6 lbs. (monitor only) 18.3 kg, 40.3 lbs. (shipping package)
Certifications	ANSI/AAMI ES60601-1 (UL60601-1), CAN/CSA C22.2 No. 60601-1, FCC Class B, EN60601-1, EN60601-1-2, CE, MDR(EU) 2017/745 Class I Medical Device

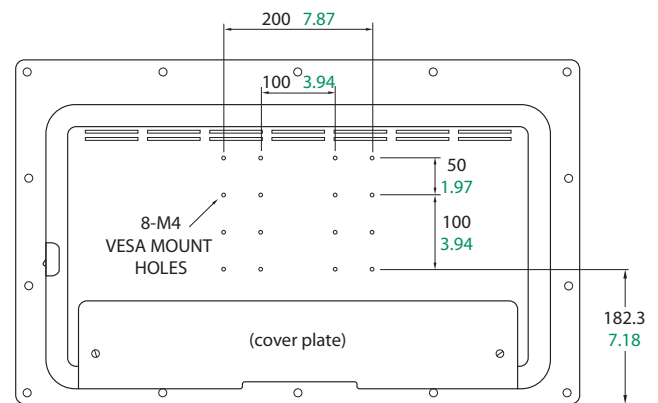
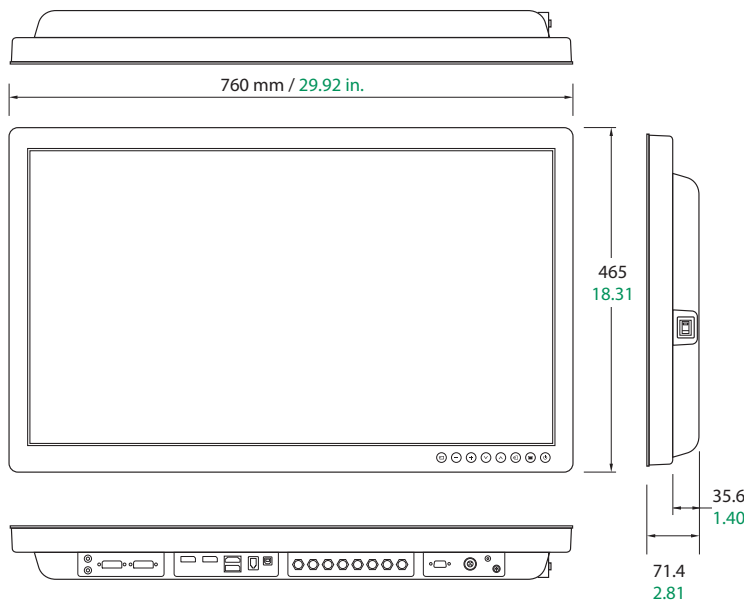

FSN Medical Technologies products meet EU RoHS Directive 2011/65/EU+2015/863/EU and Registration, Evaluation, Authorisation and Restriction of Chemicals (REACH) obligations. FSN manages the information flow as required by regulations.

Specifications are subject to change with or without notice. Doc. # FSN2090 Rev. 3/25

fsnmed.com

Foreseeson Custom Displays, Inc.

2210 E. Winston Road
Anaheim, CA 92806 USA
Tel: 714-300-0540
Fax: 714-300-0546

Latin America
Aventura, FL 33180 USA
Tel: 714-507-3855

Foreseeson Korea

B-408, U-Space2
670 Daewangpangyo-ro,
Bundang-gu, Seongnam-si
Gyeonggi-do, Republic of Korea
Tel: +82-31-8017-0780

Foreseeson GmbH

Industriestrasse 38a
63150 Heusenstamm, Germany
Tel: +49 6104 64398 0
Fax: +49 6104 64398 11

Foreseeson UK Ltd.

1 Wolsey Road
East Molesey
Surrey
KT8 9EL
United Kingdom
Tel: +44 (0) 208 546 1047

Foreseeson (Shanghai)

Medical Equipment Co., Ltd.
Room 1010, Building A
1439 Wuzhong Road
Rhein Hongjing Center
Minhang District, Shanghai, China
Tel: 18521095596